

SPECIFICATIONS:

Cable Range: 1.40"–1.75" (35.56–44.45)
 Cable Clamp Range: 1.67"–1.79" (42.3–45.5)
 Salt Spray: 48 Hours
 Approximate Breaking Strength: 1610 Lbs

REVISIONS LIST				
REV	ECO #	DESCRIPTION	DATE	APV'D
A		Initial Release		

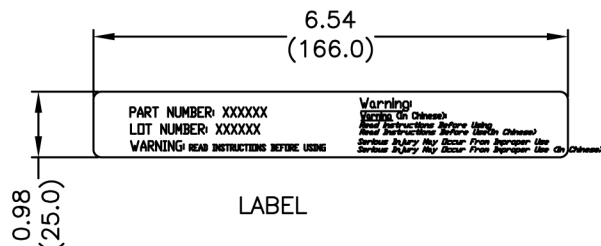
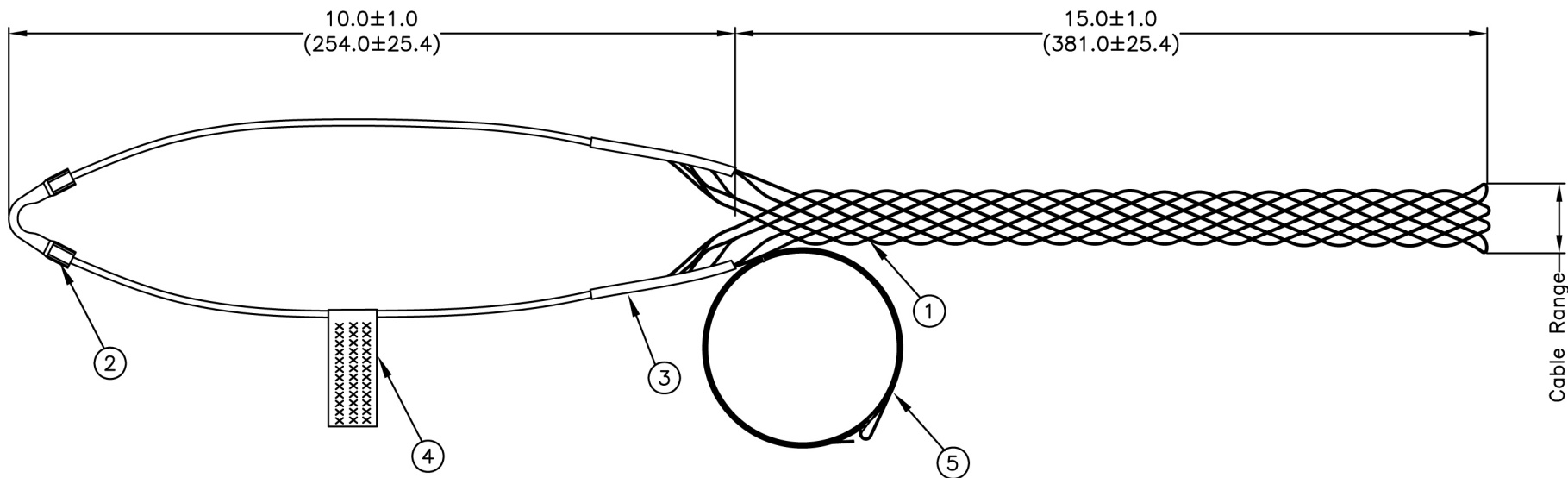

NOTES:

All Measurements Are In Inches (mm)
 All Lengths Are Measured With A 1.58" (40.1) Rod Inside.

No.	Name	Material/Finish	Remarks
1	Wire	304 Stainless Steel	1X7X1.5mm
2	Hanger	Aluminum	
3	Tubing	PVC	
4	Label	Resin Film	
5	Lace-Up Wire	304 Stainless Steel	1X7X1.5mm

UNLESS NOTED TOLERANCES ARE: .X ± 0.15 (0.38) .XX ± 0.10 (0.25) ANGLES ± 1°	THIRD ANGLE PROJECTION 	 1170 S. PATTON ST. XENIA, OHIO 45385 PH: (937) 374-2700 FX: (937) 374-2717
--	----------------------------	---

UNIT: In (mm)	DRWN: RLM	THESE DRAWINGS AND SPECIFICATIONS ARE THE PROPERTY OF SPI AND SHALL NOT BE COPIED, USED OR RE-PRODUCED WITHOUT PERMISSION.	TITLE Hoisting/Support Cord Grip (Lace-Up)	
SCALE: NTS	DATE: 07/08/11		S P I P / N : HG12-5SS1	
	CHK'D: RLM		R E V : A	
SHEET: 1 OF 1	APV'D: RLM		C U S T O M E R P / N :	