

SPECIFICATIONS:

Cable Range: 0.45"–0.65" (11.43–16.51)
 Cable Clamp Range: 0.70"–0.83" (17.8–21.0)
 Salt Spray: 48 Hours
 Approximate Breaking Strength: 530 Lbs

REVISIONS LIST				
REV	ECO #	DESCRIPTION	DATE	APV'D
A		Initial Release		

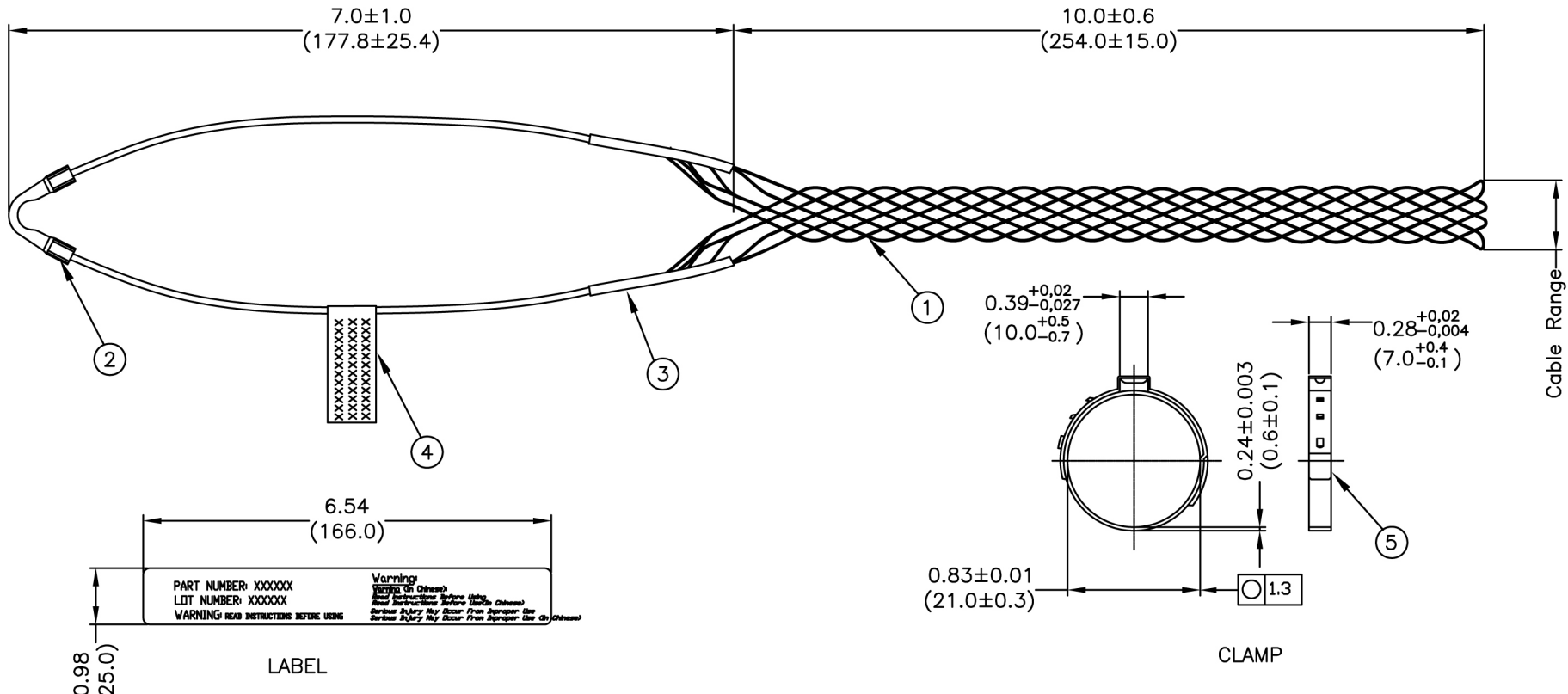

NOTES:

All Measurements Are In Inches (mm)
 All Lengths Are Measured With A 0.55" (14.0) Rod Inside.

No.	Name	Material/Finish	Remarks
1	Wire	304 Stainless Steel	1X7X1.2mm
2	Hanger	Aluminum	
3	Tubing	PVC	
4	Label	Resin Film	
5	Clamp	304 Stainless Steel	

UNLESS NOTED TOLERANCES ARE: .X ± 0.15 (0.38) .XX ± 0.10 (0.25) ANGLES ± 1°	THIRD ANGLE PROJECTION 	1170 S. PATTON ST. XENIA, OHIO 45385 PH: (937) 374-2700 FX: (937) 374-2717
--	----------------------------	---

UNIT: In (mm)	DRWN: RLM	THESE DRAWINGS AND SPECIFICATIONS ARE THE PROPERTY OF SPI AND SHALL NOT BE COPIED, USED OR RE-PRODUCED WITHOUT PERMISSION.	TITLE Hoisting/Support Cord Grip (Pre-Laced)	
SCALE: NTS	DATE: 07/08/11		S P I P / N : HG10-2SS2	
	CHK'D: RLM		R E V : A	
SHEET: 1 OF 1	APV'D: RLM		C U S T O M E R P / N :	