

**SPECIFICATIONS:**

Cable Range: 2.00"–2.50" (50.80–63.50)  
 Cable Clamp Range: 2.55"–2.68" (64.8–68.0)  
 Salt Spray: 48 Hours  
 Approximate Breaking Strength: 3260 Lbs

| REVISIONS LIST |       |                 |      |       |
|----------------|-------|-----------------|------|-------|
| REV            | ECO # | DESCRIPTION     | DATE | APV'D |
| A              |       | Initial Release |      |       |

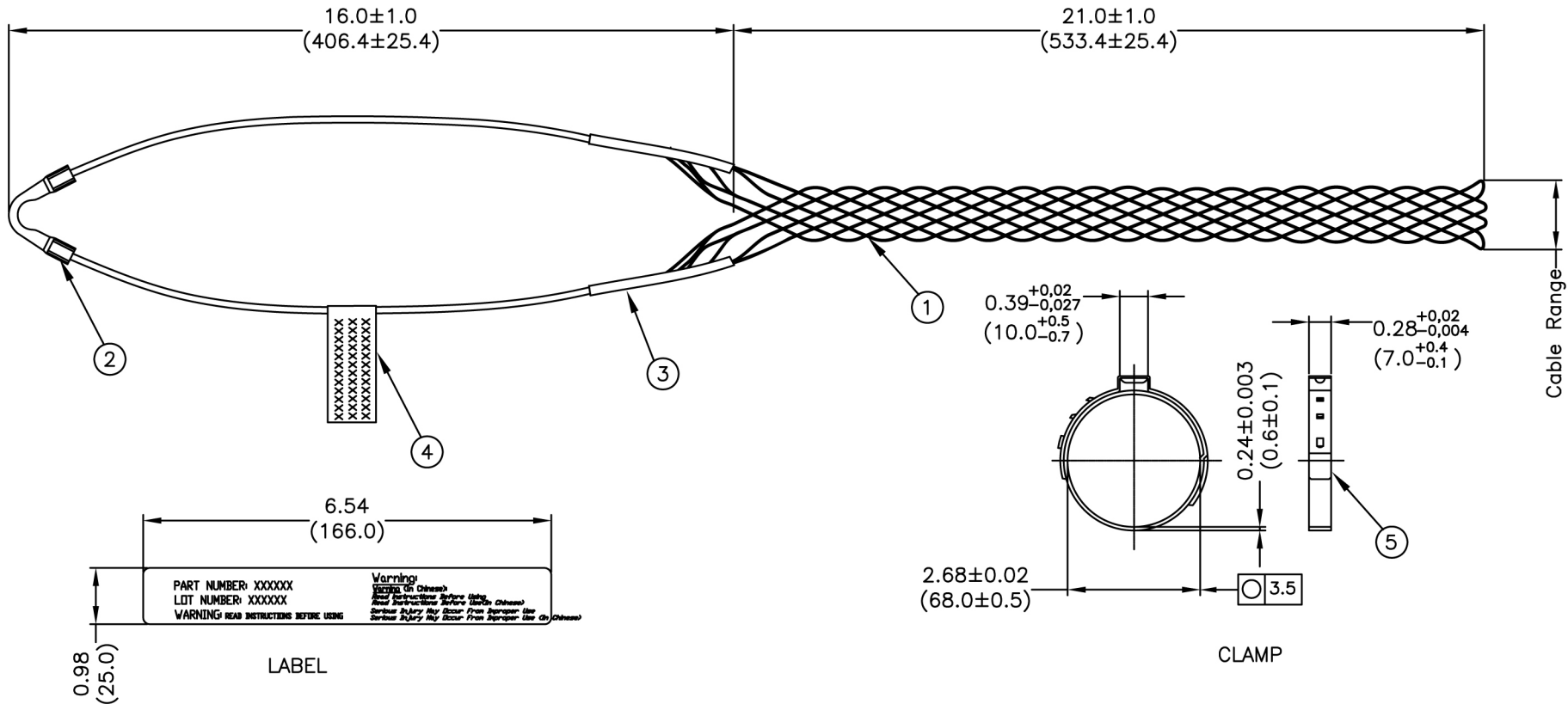

**NOTES:**

All Measurements Are In Inches (mm)  
 All Lengths Are Measured With A 2.25" (57.2) Rod Inside.

| No. | Name   | Material/Finish     | Remarks   |
|-----|--------|---------------------|-----------|
| 1   | Wire   | 304 Stainless Steel | 1X7X1.8mm |
| 2   | Hanger | Aluminum            |           |
| 3   | Tubing | PVC                 |           |
| 4   | Label  | Resin Film          |           |
| 5   | Clamp  | 304 Stainless Steel |           |

UNLESS NOTED TOLERANCES ARE:  
 .X ± 0.15 (0.38)  
 .XX ± 0.10 (0.25)  
 ANGLES ± 1°

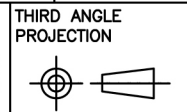

1170 S. PATTON ST.  
 XENIA, OHIO 45385  
 PH: (937) 374-2700  
 FX: (937) 374-2717

|               |                |  |   |        |
|---------------|----------------|--|---|--------|
| UNIT: In (mm) | DRWN: RLM      | THESE DRAWINGS AND SPECIFICATIONS ARE THE PROPERTY OF SPI AND SHALL NOT BE COPIED, USED OR RE-PRODUCED WITHOUT PERMISSION. | TITLE<br>Hoisting/Support Cord Grip (Pre-Laced) |        |
| SCALE: NTS    | DATE: 07/08/11 |  | S P I P / N : HG10-7SS2                         |        |
| SHEET: 1 OF 1 | APV'D: RLM     | CUSTOMER P/N:  |   | REV: A |