

SPECIFICATIONS:

Cable Range: 0.95"–1.25" (24.13–31.75)

Salt Spray: 48 Hours

Approximate Breaking Strength: 1020 Lbs

REVISIONS LIST				
REV	ECO #	DESCRIPTION	DATE	APV'D
A		Initial Release		

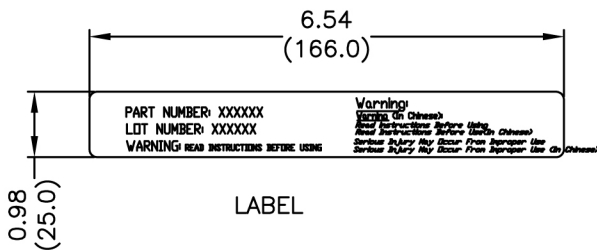
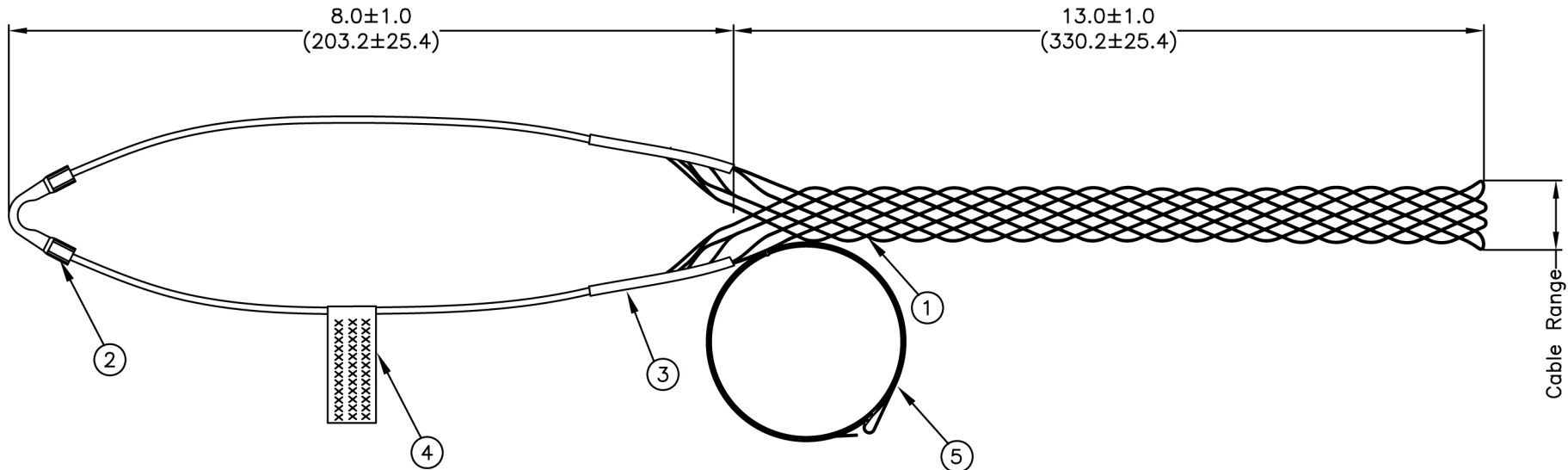

NOTES:

All Measurements Are In Inches (mm)

All Lengths Are Measured With A 1.10" (27.9) Rod Inside.

No.	Name	Material/Finish	Remarks
1	Wire	304 Stainless Steel	1X7X1.5mm
2	Hanger	Aluminum	
3	Tubing	PVC	
4	Label	Resin Film	
5	Lace-Up Wire	304 Stainless Steel	1X7X1.5mm

UNLESS NOTED TOLERANCES ARE:
 .X ± 0.15 (0.38)
 .XX ± 0.10 (0.25)
 ANGLES ± 1°

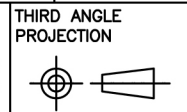

1170 S. PATTON ST.
 XENIA, OHIO 45385
 PH: (937) 374-2700
 FX: (937) 374-2717

UNIT: In (mm)	DRWN: RLM	THESE DRAWINGS AND SPECIFICATIONS ARE THE PROPERTY OF SPI AND SHALL NOT BE COPIED, USED OR RE-PRODUCED WITHOUT PERMISSION.	TITLE Hoisting/Support Cord Grip (Lace-Up)	
SCALE: NTS	DATE: 07/08/11		S P I P / N : HG12-4SS1	
	CHK'D: RLM		R E V : A	
SHEET: 1 OF 1	APV'D: RLM		C U S T O M E R P / N :	