

**SPECIFICATIONS:**

Cable Range: 0.95"–1.25" (24.13–31.75)  
 Cable Clamp Range: 1.24"–1.36" (31.4–34.6)  
 Salt Spray: 48 Hours  
 Approximate Breaking Strength: 1020 Lbs

REVISIONS LIST				
REV	ECO #	DESCRIPTION	DATE	APV'D
A		Initial Release		

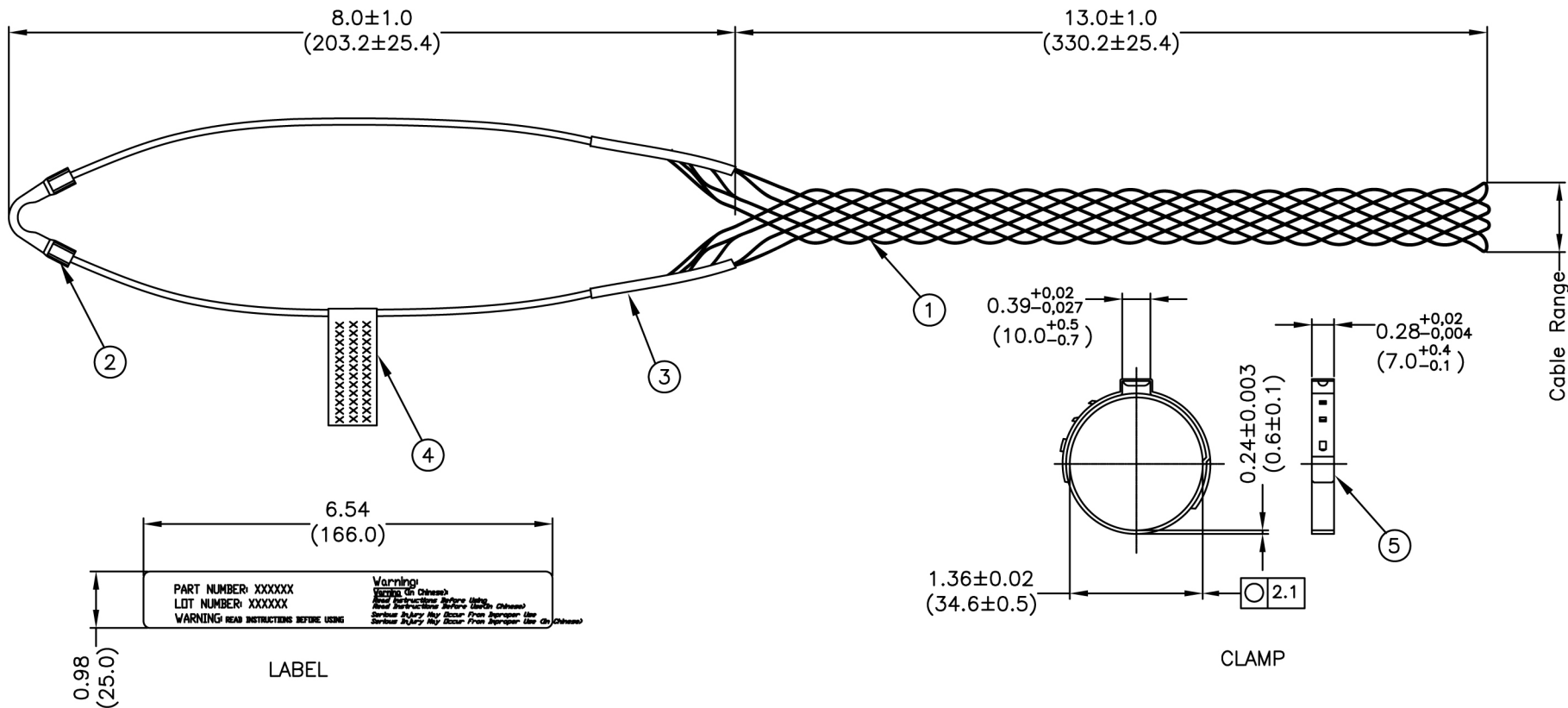

**NOTES:**

All Measurements Are In Inches (mm)  
 All Lengths Are Measured With A 1.10" (27.9) Rod Inside.

No.	Name	Material/Finish	Remarks
1	Wire	304 Stainless Steel	1X7X1.5mm
2	Hanger	Aluminum	
3	Tubing	PVC	
4	Label	Resin Film	
5	Clamp	304 Stainless Steel	

UNLESS NOTED TOLERANCES ARE: .X ± 0.15 (0.38) .XX ± 0.10 (0.25) ANGLES ± 1°	THIRD ANGLE PROJECTION 		1170 S. PATTON ST.
			XENIA, OHIO 45385
			PH: (937) 374-2700
			FX: (937) 374-2717

UNIT: In (mm)	DRWN: RLM	THESE DRAWINGS AND SPECIFICATIONS ARE THE PROPERTY OF <b>SPI</b> AND SHALL NOT BE COPIED, USED OR RE-PRODUCED WITHOUT PERMISSION.	TITLE	
SCALE: NTS	DATE: 07/08/11		Hoisting/Support Cord Grip (Pre-Laced)	
	CHK'D: RLM		SPI P/N: HG10-4SS2	REV: A
SHEET: 1 OF 1	APV'D: RLM		CUSTOMER P/N:	