

REVISIONS LIST				
REV	ECO #	DESCRIPTION	DATE	APV'D
A		Initial Release		

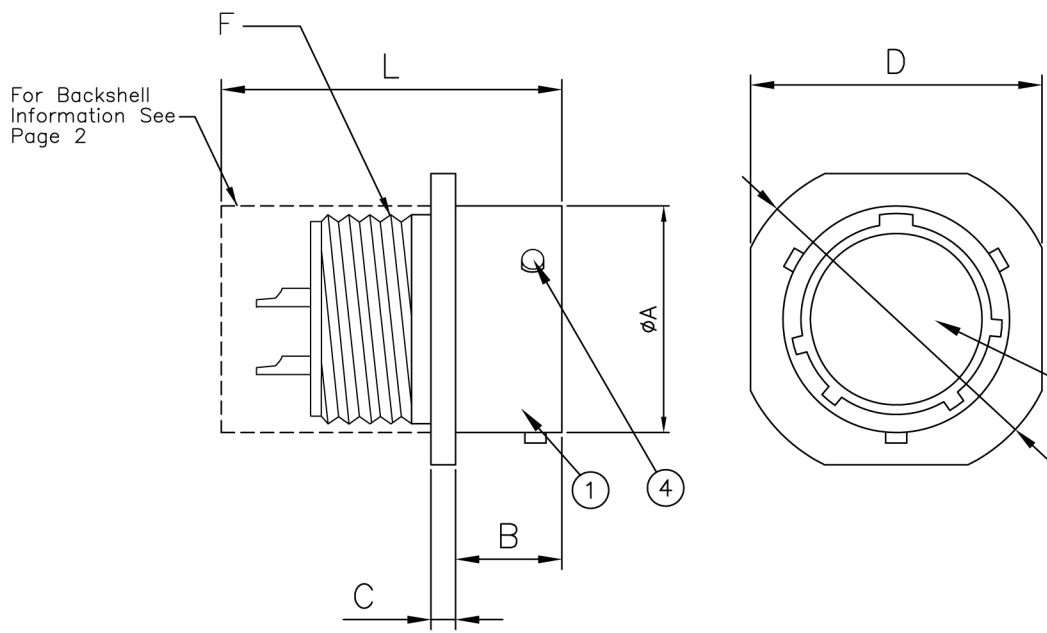

SPECIFICATIONS

Mechanical

Engagement Force-Torque (Max)	.902-4.97 N-m
Disengagement Force-Torque (Min)	.113-.791 N-m
Durability	500 Cycles
Insert Retention	5.3 Kg/cm ²
Contact Retention (Min)	
20 Gauge	67 N
16 Gauge	113 N
Contact Engagement Force (Max)	
20 Gauge	5.0 N
16 Gauge	8.34 N
Contact Separation Force (Min)	
20 Gauge	.195 N
16 Gauge	.556 N

Electrical

Current Rating (Max)	
20 Gauge	7.5A
16 Gauge	22.0A
Contact Resistance	As specified in Table VII MIL-DTL-26482
Insulation Resistance (@500 VDC)	
(25°C)	5000 MΩ
Short Time (125°C)	3 MΩ
Long Time (105°C)	12 MΩ
Dielectric Withstanding Voltage (Working)	
SL (Service Rating I)	600 VAC (rms)
(Service Rating II)	1000 VAC (rms)
70,000 Ft (Service Rating I)	300 VAC (rms)
(Service Rating II)	450 VAC (rms)

Environmental

Operating Temperature	-55°C - +125°C
Air Leakage (@2.11 Kg/cm ²)	<4.55X10 ⁻³ cm ³ /s
Salt Spray (@35°C)	48 Hrs
Vibration (10-2000Hz)	12 Hrs
Shock (Peak Acceleration)	490 m/s ² (50g's)

NOTE: Service Rating is identified on each insert arrangement

Shell Size	A MAX	B +0.79 -0.00	C ±0.41	D MAX	E ±0.51	F THREAD (UNEF2A)
8	12.04	10.16	2.39	21.03	23.83	.4375-28
10	15.01	10.16	2.39	24.23	26.97	.5625-24
12	19.08	10.16	2.39	26.59	29.36	.6875-24
14	22.25	10.16	2.39	28.98	31.75	.8125-20
16	25.43	10.16	2.39	31.34	34.14	.9375-20
18	28.60	10.16	2.39	33.73	36.53	1.0625-18
20	31.78	13.59	2.92	36.91	39.67	1.1875-18
22	34.95	13.59	2.92	40.08	42.88	1.3125-18
24	38.12	14.17	2.92	43.18	46.02	1.4375-18

No.	Name	Material/Finish	Remarks
1	Shell	Aluminum	
2	Insert	Neoprene	
3	Contact	Copper Alloy	Ni 100μ" - Au 50μ"
4	Locking Post	304 Stainless Steel	

UNLESS NOTED TOLERANCES ARE: .X ± 0.38 .XX ± 0.25 ANGLES ± 1°	THIRD ANGLE PROJECTION		1170 S. PATTON ST. XENIA, OHIO 45385 PH: (937) 374-2700 FX: (937) 374-2717
UNIT: mm SCALE: NTS SHEET: 1 OF 2	DRWN: RLM DATE: 01/29/14 CHK'D: RLM APV'D: RLM	THESE DRAWINGS AND SPECIFICATIONS ARE THE PROPERTY OF SPI AND SHALL NOT BE COPIED, USED OR RE-PRODUCED WITHOUT PERMISSION.	TITLE MIL-DTL-26482 Cable Mount Receptacle SPI P / N : MS3111XXX-XXXX CUSTOMER P / N :

REV : A

REVISIONS LIST				
REV	ECO #	DESCRIPTION	DATE	APV'D
A		Initial Release		

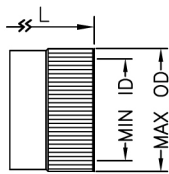

GROMMET SEAL WITH BACK NUT [E]

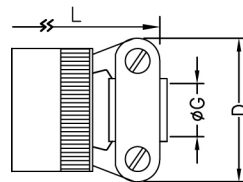

GROMMET SEAL WITH STRAIN RELIEF [F]

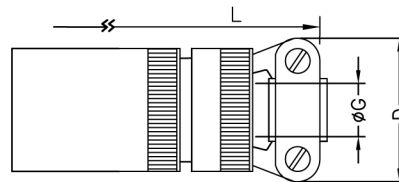

WATER TIGHT GLAND SEAL WITH STRAIN RELIEF [J]

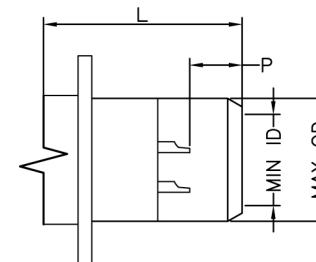

ENVIRONMENTAL POTTING [P]

Shell Size	CLASS E			CLASS F			CLASS J				CLASS P			
	L MAX	ID MIN	OD MAX	L MAX	D MAX	$\phi G \pm .254$	L MAX	D MAX	GLAND CLOSED	ϕG OPEN	L MAX	ID MIN	OD MAX	P MIN
8	33.73	6.58	15.44	48.82	21.03	3.18	57.68	21.03	4.29	5.84	36.91	8.05	15.44	6.35
10	33.73	9.12	18.64	48.82	22.63	4.78	57.68	22.63	5.21	7.92	39.91	11.02	18.64	6.35
12	33.73	11.91	21.79	48.82	25.81	7.92	61.24	25.81	8.59	11.23	36.91	13.92	21.79	6.35
14	33.73	14.96	24.99	48.82	28.98	9.53	66.01	28.98	10.57	13.69	36.91	17.09	24.99	6.35
16	33.73	18.47	28.19	51.99	30.56	12.70	74.75	30.56	13.97	15.65	36.91	20.27	28.19	6.35
18	33.73	19.79	31.34	52.78	37.31	15.88	80.57	37.31	15.24	17.07	36.91	22.83	31.34	6.35
20	38.89	22.89	34.54	59.54	37.31	15.88	91.69	37.31	16.13	18.97	42.47	26.01	34.54	6.35
22	38.89	25.63	37.69	59.54	42.06	19.05	95.66	42.06	17.02	21.49	42.47	29.18	37.69	6.35
24	40.49	28.52	40.89	61.11	44.45	20.32	101.22	44.45	19.30	22.69	44.04	32.36	40.89	6.35

Name	Material/Finish	Remarks
Back Shells & Clamps	Aluminum	
Screws	Brass	
Washers	Stainless Steel	F & J Back Shells
Grommets/O-Rings	Neoprene	
Gland Seal	Silicone	

UNLESS NOTED TOLERANCES ARE:
 .X ± 0.38
 .XX ± 0.25
 ANGLES $\pm 1^\circ$

THIRD ANGLE PROJECTION

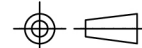

1170 S. PATTON ST.
 XENIA, OHIO 45385
 PH: (937) 374-2700
 FX: (937) 374-2717

UNIT: mm	DRWN: RLM	THESE DRAWINGS AND SPECIFICATIONS ARE THE PROPERTY OF SPI AND SHALL NOT BE COPIED, USED OR RE-PRODUCED WITHOUT PERMISSION.	TITLE
SCALE: NTS	DATE: 01/29/14		MIL-DTL-26482 Cable Mount Receptacle
	CHK'D: RLM		SPI P/N: MS3111XXX-XXXX
SHEET: 2 OF 2	APV'D: RLM		REVISION: A
			CUSTOMER P/N: