

SPECIFICATIONS:

Cable Range: 1.010"–1.160" (25.65–29.46)

Salt Spray: 500 Hours

Cable Pull Out Strength: 250 Lbs for 1 Hour

MIL-DTL-22992 QPL Qualified

REVISIONS LIST				
REV	ECO #	DESCRIPTION	DATE	APV'D
A		Initial Release		

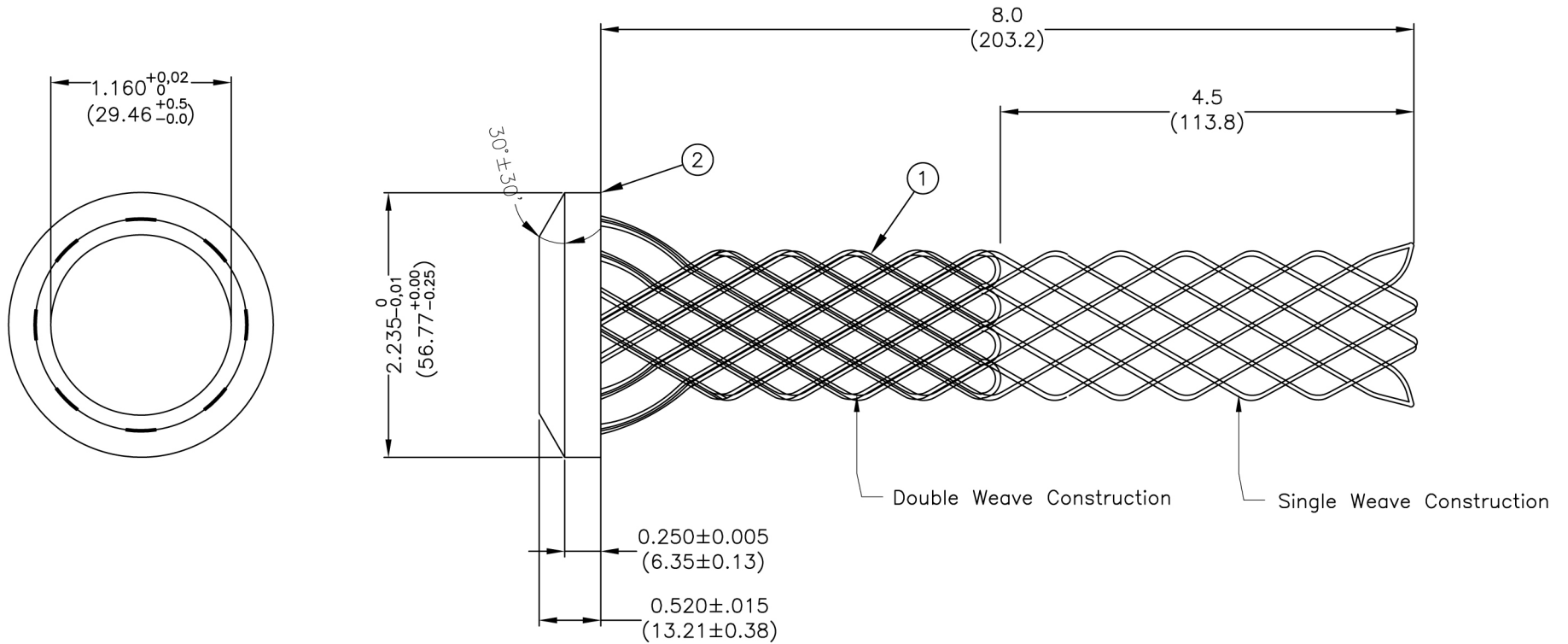

NOTES:

All Measurements Are In Inches (mm)

No.	Name	Material/Finish	Remarks
1	Wire	304 Stainless Steel	1X7X1.25mm
2	Ring	304 Stainless Steel	

UNLESS NOTED TOLERANCES ARE:
 .X ± 0.15 (0.38)
 .XX ± 0.10 (0.25)
 ANGLES ± 1'

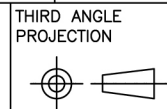

1170 S. PATTON ST.
 XENIA, OHIO 45385
 PH: (937) 374-2700
 FX: (937) 374-2717

UNIT: In (mm)	DRWN: RLM	THESE DRAWINGS AND SPECIFICATIONS ARE THE PROPERTY OF SPI AND SHALL NOT BE COPIED, USED OR RE-PRODUCED WITHOUT PERMISSION.	TITLE	
SCALE: NTS	DATE: 12/14/09		Class L Cord Grip	
	CHK'D: RLM		SPI P / N : MS90561-21	REV : A
SHEET: 1 OF 1	APV'D: RLM		CUSTOMER P / N:	