

REVISIONS LIST				
REV	ECO #	DESCRIPTION	DATE	APV'D
A		Initial Release		

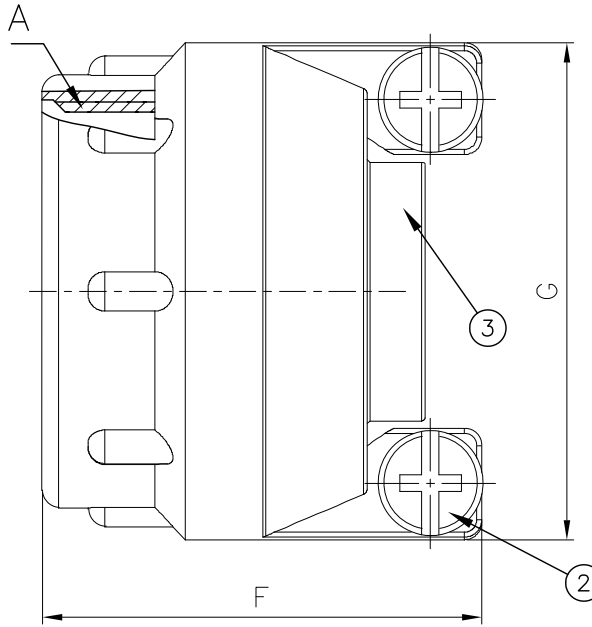
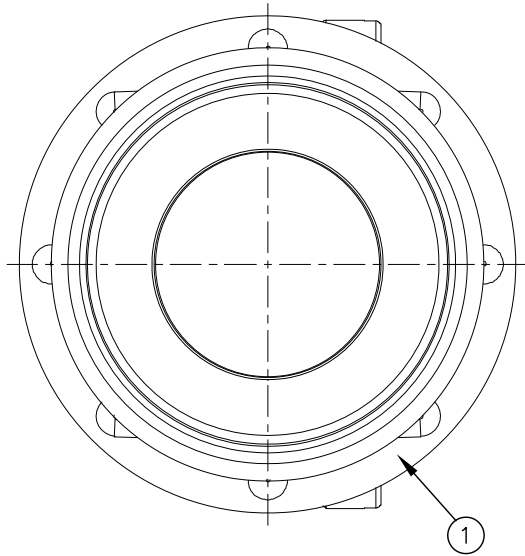

Shell Size	A Thread (Class: 2B)	F Max	G Max
16S, 16 (-8A)	0.875-20	26.2	30.2
18 (-10A)	1.000-20	27.8	33.3
20, 22 (-12A)	1.1875-18	31.0	39.7
24, 28 (-16A)	1.4375-18	31.0	44.5

No.	Name	Material/Finish	Remarks
1	Shell	Aluminum	
2	Screw	Stainless Steel	
3	Seal	Neoprene	

UNLESS NOTED TOLERANCES ARE: .X ± 0.38 .XX ± 0.25 ANGLES ± 1°	THIRD ANGLE PROJECTION 	 1170 S. PATTON ST. XENIA, OHIO 45385 PH: (937) 374-2700 FX: (937) 374-2717
--	----------------------------	---

UNIT: mm	DRWN: RLM	THESE DRAWINGS AND SPECIFICATIONS ARE THE PROPERTY OF  AND SHALL NOT BE COPIED, USED OR RE-PRODUCED WITHOUT PERMISSION.	TITLE Commercial 5015 Cable Seal with Grounding	
SCALE: NTS	DATE: 01/11/18		SPI P/N: S-MS3057B-XX-XX	REV: A
	CHK'D: TRH		CUSTOMER P/N:	
SHEET: 1 OF	APV'D: TRH			