

REVISIONS LIST				
REV	ECO #	DESCRIPTION	DATE	APV'D
A		Initial Release		

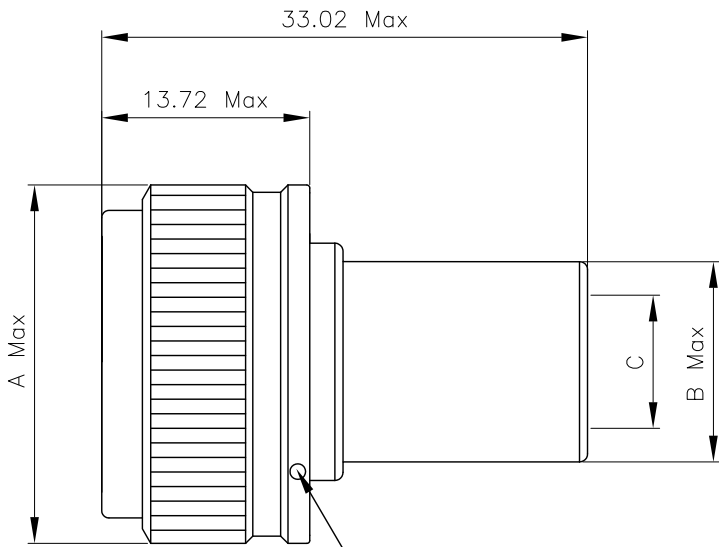

3 EQUALLY SPACED 0.51 MAX SAFETY WIRE HOLES

Shell Size	A Max	B Max	C ±0.38	SPI85049/26-2 Ring Shield Crimp (Ref)
9	19.01	8.81	6.35	-8
11	21.60	12.65	8.26	-10
13	25.40	12.95	10.67	-12
15	27.90	16.00	13.72	-14
17	31.80	19.30	17.02	-16
19	35.60	22.61	20.04	-18
21	38.10	25.65	23.22	-20
23	41.90	28.70	26.39	-22
25	44.50	30.53	28.24	-24

Note: If a crimp ring shield is necessary order SPI85049/26-2-X using the above reference for the proper shell size

No.	Name	Material/Finish	Remarks
1	Shell	Aluminum	
2	Fastners	Stainless Steel	Passivated

UNLESS NOTED TOLERANCES ARE: .X ± 0.38 .XX ± 0.25 ANGLES ± 1°	THIRD ANGLE PROJECTION 		1170 S. PATTON ST. XENIA, OHIO 45385 PH: (937) 374-2700 FX: (937) 374-2717
--	----------------------------	--	---

UNIT: mm	DRWN: RLM	THESE DRAWINGS AND SPECIFICATIONS ARE THE PROPERTY OF SPI AND SHALL NOT BE COPIED, USED OR RE-PRODUCED WITHOUT PERMISSION.	TITLE		
SCALE: NTS	DATE: 08/30/21		Commercial Back Shell		
	CHK'D: TRH		SPI P / N: SPI85049/20-XXX		REV: A
SHEET: 1 OF 1	APV'D: TRH		CUSTOMER P / N:		