

REVISIONS LIST				
REV	ECO #	DESCRIPTION	DATE	APV'D
A		Initial Release		

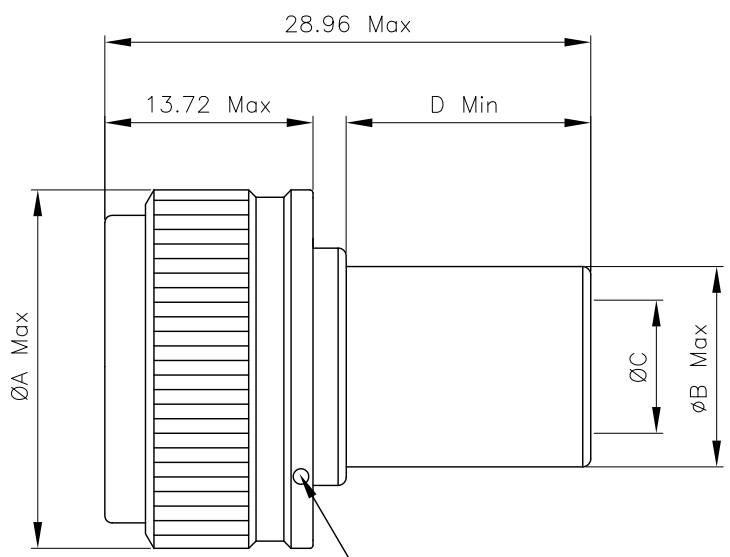

3 EQUALLY SPACED 0.51 MAX SAFETY WIRE HOLES

Dash Number	ØA Max	ØB ±0.25	ØC ±0.38	D Min	M85049/26-2 Ring Shield Crimp (Ref)
08	19.05	8.56	6.35	7.24	-8
10	21.59	12.40	8.26	12.07	-10
12	25.40	12.70	10.67	12.07	-12
14	27.94	15.75	13.72	12.07	-14
16	31.75	19.05	17.02	12.07	-16
18	35.56	22.35	20.04	12.07	-18
20	38.10	25.40	23.22	12.07	-20
22	41.91	28.45	26.39	12.07	-22
24	44.45	30.28	28.24	12.07	-24

Note: If a crimp ring shield is necessary order SPI85049/26-2-X using the above reference for the proper shell size

No.	Name	Material/Finish	Remarks
1	Shell	Aluminum	
2	Fastners	Stainless Steel	Passivated

UNLESS NOTED TOLERANCES ARE: .X ± 0.38 .XX ± 0.25 ANGLES ± 1°	THIRD ANGLE PROJECTION 		1170 S. PATTON ST. XENIA, OHIO 45385 PH: (937) 374-2700 FX: (937) 374-2717
--	----------------------------	--	---

UNIT: mm	DRWN: RLM	THESE DRAWINGS AND SPECIFICATIONS ARE THE PROPERTY OF SPI AND SHALL NOT BE COPIED, USED OR RE-PRODUCED WITHOUT PERMISSION.	TITLE Commercial Back Shell	
SCALE: NTS	DATE: 08/30/21		SPI P / N : SPI85049/33-2-XXX	
	CHK'D: TRH		REV: A	
SHEET: 1 OF 1	APV'D: TRH		CUSTOMER P / N :	