

REVISIONS LIST				
REV	ECO #	DESCRIPTION	DATE	APV'D
A		Initial Release		

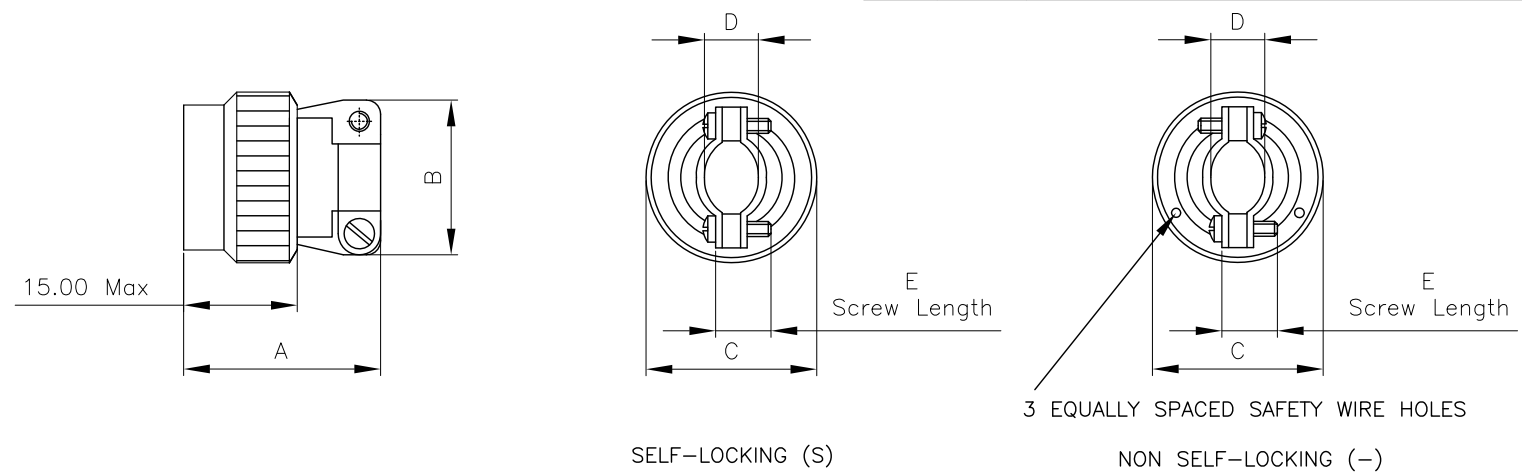

Dash Number	S Configuration							- Configuration						
	A	B	C	D		E	Screw Size	A	B	C	D		E	Screw Size
	Max	Max	Max	Min	Max	0.0/-1.57		Max	Max	Max	Min	Max	0.0/-1.57	
8	29.20	21.60	21.82	2.49	5.94	12.70	6-32	27.90	21.60	19.10	2.49	5.94	12.70	6-32
10	29.20	22.90	24.99	3.89	5.94	12.70	6-32	27.90	22.90	21.60	3.89	5.94	12.70	6-32
12	31.80	27.90	29.36	4.83	8.33	15.88	6-32	30.50	27.90	25.40	4.83	8.33	15.88	6-32
14	33.00	29.20	32.54	6.60	11.61	19.05	6-32	31.80	29.20	27.90	6.60	11.61	19.05	6-32
16	35.60	33.00	35.71	7.19	15.60	19.05	6-32	34.30	33.00	31.80	7.19	15.60	19.05	6-32
18	41.90	38.10	38.51	8.26	16.10	19.05	8-32	40.60	38.10	35.60	8.26	16.10	19.05	8-32
20	44.50	40.60	41.68	8.71	17.73	22.23	8-32	43.20	40.60	38.10	8.71	17.73	22.23	8-32
22	48.30	43.20	44.86	9.68	20.90	25.40	8-32	47.00	43.20	41.90	9.68	20.90	25.40	8-32
24	50.80	45.70	48.03	10.62	21.67	28.58	8-32	49.50	45.70	44.50	10.62	21.67	28.58	8-32

No.	Name	Material/Finish	Remarks
1	Shell	Aluminum	
2	Fasteners	Stainless Steel	Passivated

UNLESS NOTED TOLERANCES ARE: .X ± 0.38 .XX ± 0.25 ANGLES ± 1°	THIRD ANGLE PROJECTION 		1170 S. PATTON ST. XENIA, OHIO 45385 PH: (937) 374-2700 FX: (937) 374-2717
--	----------------------------	--	---

UNIT: mm	DRWN: RLM	THESE DRAWINGS AND SPECIFICATIONS ARE THE PROPERTY OF SPI AND SHALL NOT BE COPIED, USED OR RE-PRODUCED WITHOUT PERMISSION.	TITLE	
SCALE: NTS	DATE: 08/30/21		Commercial Back Shell	
	CHK'D: TRH		SPI P/N: SPI85049/49-2XXX	REV: A
SHEET: 1 OF 1	APV'D: TRH		CUSTOMER P/N:	