

REVISIONS LIST				
REV	ECO #	DESCRIPTION	DATE	APV'D
A		Initial Release		

SPECIFICATIONS

<u>Mechanical</u>	
Engagement Force-Torque (Max)	.902-4.97 N-m
Disengagement Force-Torque (Min)	.113-.791 N-m
Durability	500 Cycles
Insert Retention	5.3 Kg/cm ²
Contact Retention (Min)	
20 Gauge	67 N
16 Gauge	113 N
Contact Engagement Force (Max)	
20 Gauge	5.0 N
16 Gauge	8.34 N
Contact Separation Force (Min)	
20 Gauge	.195 N
16 Gauge	.556 N
<u>Electrical</u>	
Current Rating (Max)	
20 Gauge	7.5A
16 Gauge	22.0A
Contact Resistance	As specified in Table VII MIL-DTL-26482
Insulation Resistance (@500 VDC)	
(25°C)	5000 MΩ
Short Time (125°C)	3 MΩ
Long Time (105°C)	12 MΩ
Dielectric Withstanding Voltage (Working)	
SL (Service Rating I)	600 VAC (rms)
(Service Rating II)	1000 VAC (rms)
70,000 Ft (Service Rating I)	300 VAC (rms)
(Service Rating II)	450 VAC (rms)
<u>Environmental</u>	
Operating Temperature	-55°C - +125°C
Air Leakage (@2.11 Kg/cm ²)	<4.55X10 ⁻³ cm ³ /s
Salt Spray (@35°C)	48 Hrs
Vibration (10-2000Hz)	12 Hrs
Shock (Peak Acceleration)	490 m/s ² (50g's)

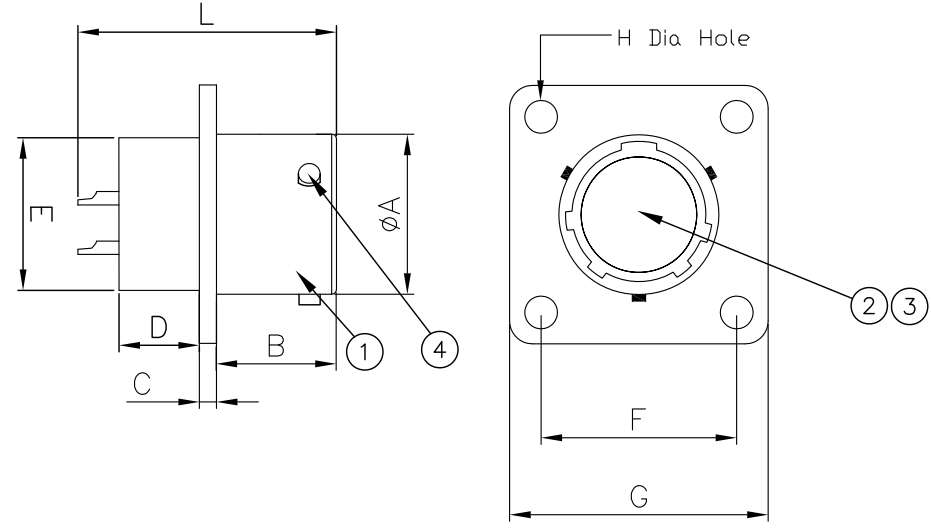

Shell Size	A MAX	B +0.79 -0.00	C ±0.41	D MAX	E +0.79 -0.41	F TP	G MAX	H ±0.127	L MAX
8	12.04	10.95	1.57	8.99	11.12	15.09	21.03	3.05	24.84
10	15.01	10.95	1.57	8.99	14.27	18.26	24.23	3.05	24.84
12	19.08	10.95	1.57	8.99	17.48	20.62	26.59	3.05	24.84
14	22.25	10.95	1.57	8.99	20.62	23.01	28.98	3.05	24.84
16	25.43	10.95	1.57	8.99	23.83	24.61	31.34	3.05	24.84
18	28.60	10.95	1.57	8.99	26.97	26.97	33.73	3.05	24.84
20	31.78	14.12	2.39	10.59	30.17	29.36	36.91	3.05	30.38
22	34.95	14.12	2.39	10.59	33.32	31.75	40.08	3.05	30.38
24	38.12	14.96	2.39	11.30	36.53	34.93	43.26	3.73	30.38

NOTE: Service Rating is identified on each insert arrangement

No.	Name	Material/Finish	Remarks
1	Shell	Aluminum	
2	Insert	Neoprene	
3	Contact	Copper Alloy	Ni 100μ" - Au 50μ"
4	Locking Post	304 Stainless Steel	

UNLESS NOTED TOLERANCES ARE:
.X ± 0.38
.XX ± 0.25
ANGLES ± 1°

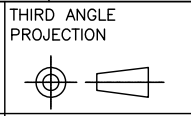

1170 S. PATTON ST.
XENIA, OHIO 45385
PH: (937) 374-2700
FX: (937) 374-2717

UNIT: mm	DRWN: RLM	THESE DRAWINGS AND SPECIFICATIONS ARE THE PROPERTY OF SPI AND SHALL NOT BE COPIED, USED OR RE-PRODUCED WITHOUT PERMISSION.	TITLE	
SCALE: NTS	DATE: 01/29/14		MIL-DTL-26482 Box Mount Receptacle	
	CHK'D: RLM		SPI P/N: MS3112EXX-XXXX	REV: A
SHEET: 1 OF 1	APV'D: RLM		CUSTOMER P/N:	