

**SPECIFICATIONS:**

Cable Range: 1.531"–1.688" (38.89–42.88)  
 Salt Spray: 500 Hours  
 Cable Pull Out Strength: 250 Lbs for 1 Hour  
 MIL-DTL-22992 QPL Qualified

REVISIONS LIST				
REV	ECO #	DESCRIPTION	DATE	APV'D
A		Initial Release		

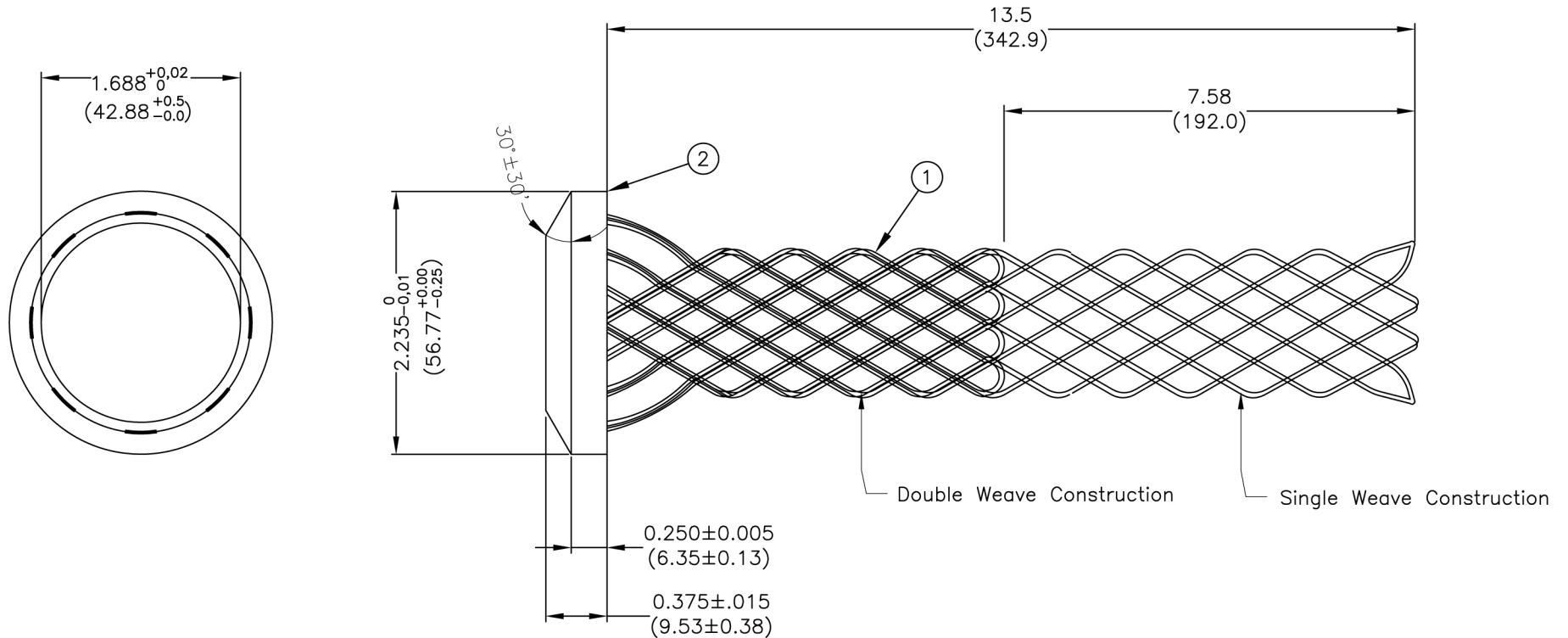

**NOTES:**

All Measurements Are In Inches (mm)

No.	Name	Material/Finish	Remarks
1	Wire	304 Stainless Steel	1X7X1.25mm
2	Ring	304 Stainless Steel	

UNLESS NOTED TOLERANCES ARE: .X ± 0.15 (0.38) .XX ± 0.10 (0.25) ANGLES ± 1°	THIRD ANGLE PROJECTION 		1170 S. PATTON ST. XENIA, OHIO 45385 PH: (937) 374-2700 FX: (937) 374-2717
--	----------------------------	--	---

UNIT: In (mm)	DRWN: RLM	THESE DRAWINGS AND SPECIFICATIONS ARE THE PROPERTY OF <b>SPI</b> AND SHALL NOT BE COPIED, USED OR RE-PRODUCED WITHOUT PERMISSION.	TITLE Class L Cord Grip	
SCALE: NTS	DATE: 12/14/09		S P I P / N : MS90561-16	
	CHK'D: RLM		R E V : A	
SHEET: 1 OF 1	APV'D: RLM		C U S T O M E R P / N :	